

# **ANGLgear<sup>®</sup>**

**right angle drives**  
*Inch and Metric Series*

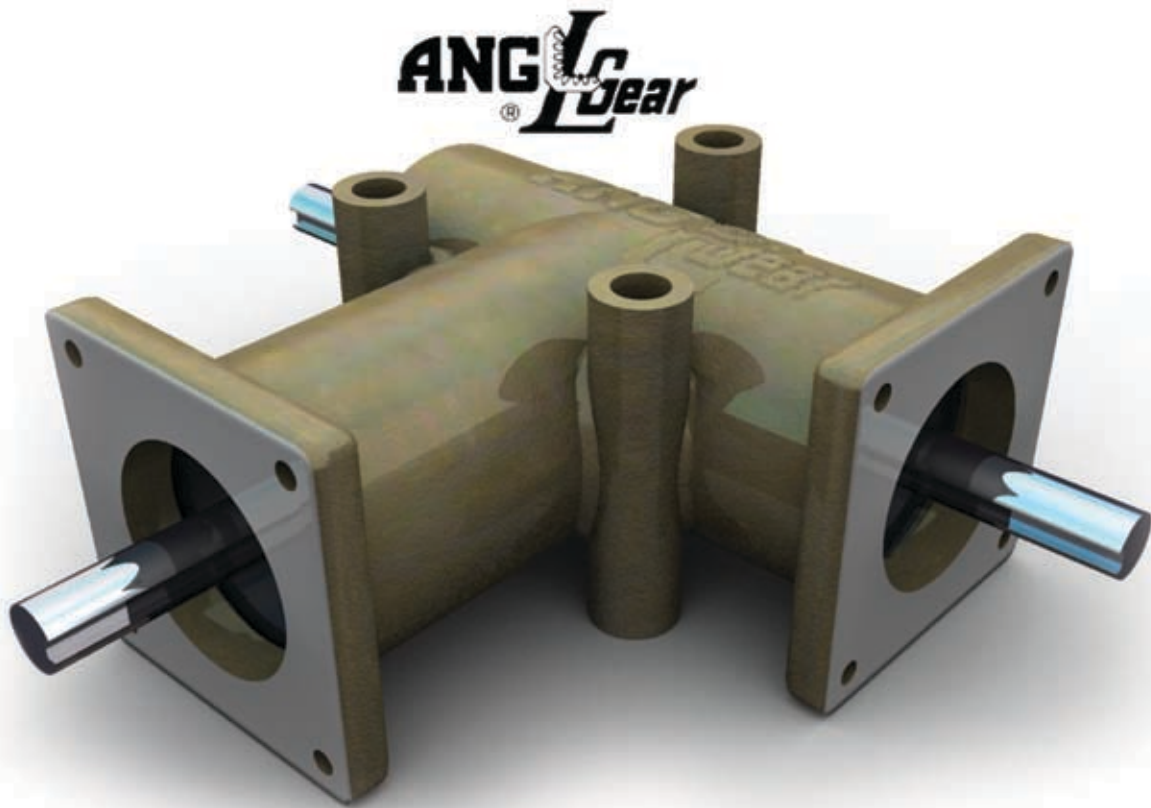

***“The Original Right Angle Gear Drive”***  
*Made in the U.S.A.*

**ANDANTE<sup>X</sup>**  
USA Inc.

Intro to ANGLgear Inch & Metric Series	pg. 2-3
2 Flange Units, Inch Series	pg. 4
3 Flange Units, Inch Series	pg. 5
Selection & Ordering Information, Inch Series	pg. 6
2 Flange Units, Metric Series	pg. 7
3 Flange Units, Metric Series	pg. 8
Selection & Ordering Information, Metric Series	pg. 9
Special Units Inch & Metric Series	pg. 10

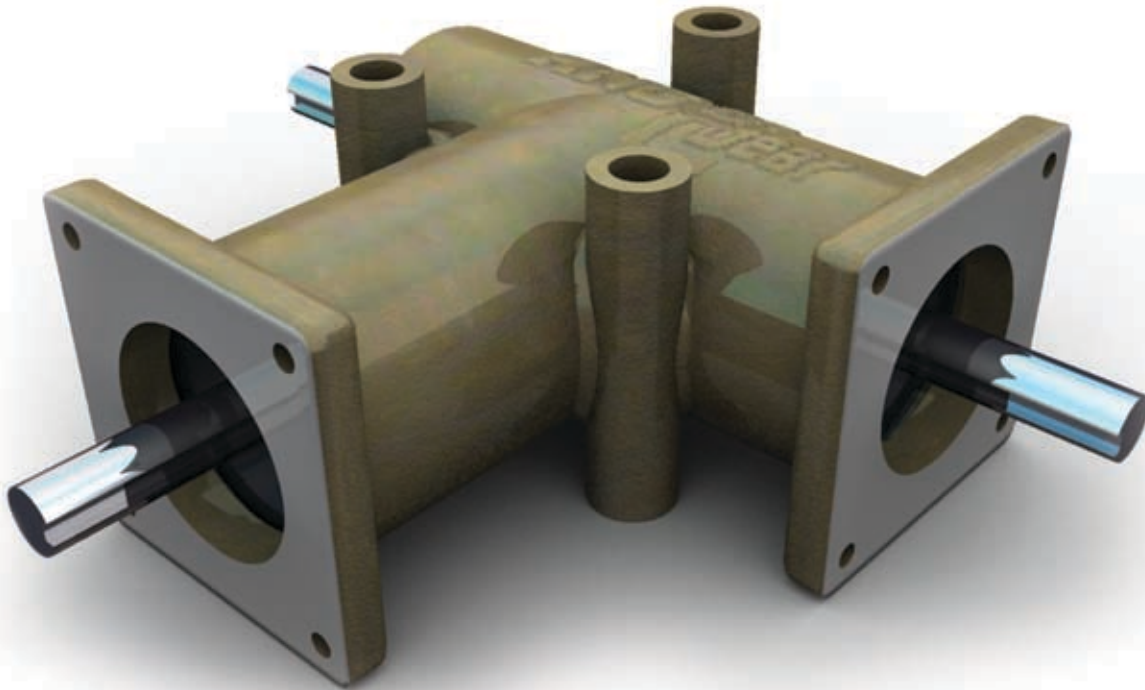

## The Original Right-Angle Gear Drive

The ANGLgear line of bevel gearboxes has proven its performance for over 40 years. It was developed to provide manual or power transmission of rotary motion in a compact, standardized right-angle unit. Each ANGLgear is manufactured at our factory in Wanamassa, NJ, USA. All units are inspected and tested to ensure proper operation at the rated speeds.

The ANGLgear name is widely recognized and the product is in use worldwide. We also offer a line of metric ANGLgears for use in designs needing metric shaft diameters and mounting surfaces.

Utilizing carburized case-hardened Coniflex\* bevel gears, all ANGLgear units employ completely enclosed and sealed ball bearings and are lubricated for life. The cast aluminum housings are precision machined, and use flanged ends and side bosses for compact installation in a wide range of applications.

Special and/or modified units are our specialty! At Andantex USA, we will modify our standard designs to fit your design specifications. For more information about our special gearboxes, refer to page 10 or consult the factory. Our Sales and Engineering departments are ready to help you with your specific application requirements.

\*Trademark – The Gleason Works, Rochester, NY

## ANGLgear Quality Specifications for both Inch and Metric Series:

Every ANGLgear manufactured is tested to meet our quality specifications and are 100% inspected prior to packaging. This process ensures a consistent quality of our gearboxes, and filters out units that might become a problem if installed in an application.

### NOISE LEVEL

Experience has proven that noise level testing and inspection provide an accurate indication of operational efficiency. All ANGLgear units are tested to meet the following maximum noise levels for acceptance:

Size 1 – R3000/R3003:	73 dB
R3100/R3103:	74 dB
Size 2 – R3200/R3203:	77 dB
R3300/R3303:	78 dB
Size 3 – R3330/R3350:	89 dB
Size 4 – R3400/R3500:	89 dB
Size 5 – R3570/R3590:	89 dB

For special applications requiring reduced noise levels, please consult the factory.

### BACKLASH

Each unit is checked for its gear mesh backlash to ensure it is within the prescribed backlash range. For Size 1, the backlash range is 1/4° to 3/4°. For Sizes 2 through 5, the backlash is 1/8° to 1/2°. For special applications requiring reduced backlash, please consult the factory.

### MILITARY SPECIFICATIONS

Andantex USA meets MIL-I-45208A for Inspection System Requirements. We can conform to military contracts specifying various MIL-SPEC requirements.

### LUBRICATION

ANGLgear units are lubricated for life. All models are lubricated with Exxon Beacon 325 grease, having an operating temperature range from -65°F to +200°F (-54°C to +93°C). Different greases can be supplied upon request.

## ANGLgear Quality Specifications:

### BEVEL GEARS

All gears in the ANGLgear product line are cut using the Gleason Generating System to a AGMA Quality Class 9. This system develops straight bevel Coniflex tooth profiles, which are crowned at the center of the tooth. This allows for better tooth meshing, and operating pitchline velocities of over 1000 feet per minute. All gears are then carburized case hardened to ensure a long operating life.

### BEARINGS

There are four ball bearings in each ANGLgear unit. Each bearing is packed with Exxon Beacon 325 Grease and sealed with two Buna-N seals. The bearings are lubricated for life. Special seals such as Viton and Teflon can be provided for high temperature applications.

### HOUSING

The housings are aluminum alloy castings. Each housing is precision machined on our CNC machining center and then coated with a chemical film to protect the material. We can offer special materials and coatings for further protection in corrosive environments, and special machining for precision mounting and alignment.

### SHAFTS

The shaft material for Sizes 1, 2 and 3 is #416 stainless steel. \*\*On 2:1 models, the pinion shaft is cadmium-plated carbon steel. For Sizes 4 and 5, the shaft material is black-oxide carbon steel. We can offer a variety of materials and treatments to meet your design specifications. Shafts can be provided with special extensions (with flats, splines, holes, etc.) and/or specific lengths upon request.

Grease Lubricated

Hardened Coniflex Straight Bevel Gears

Universal Mounting Positions

Double Sealed Ball Bearings

Cast Aluminum Housings

Stainless Steel Shafts Type 416\*\*

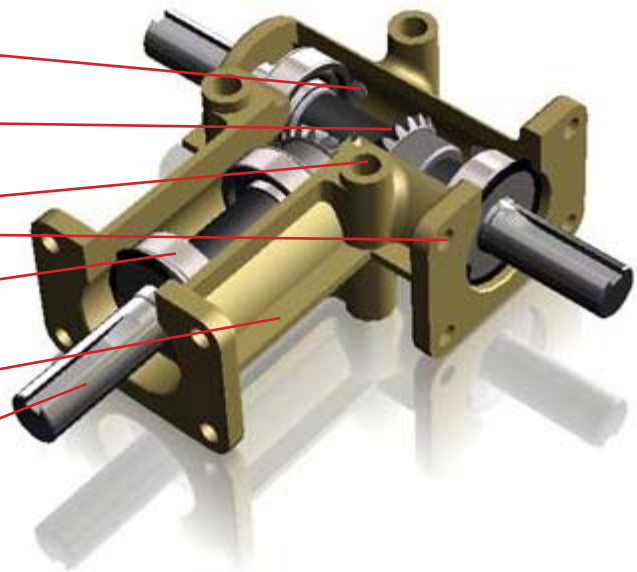

## 2 FLANGE UNITS, INCH SERIES

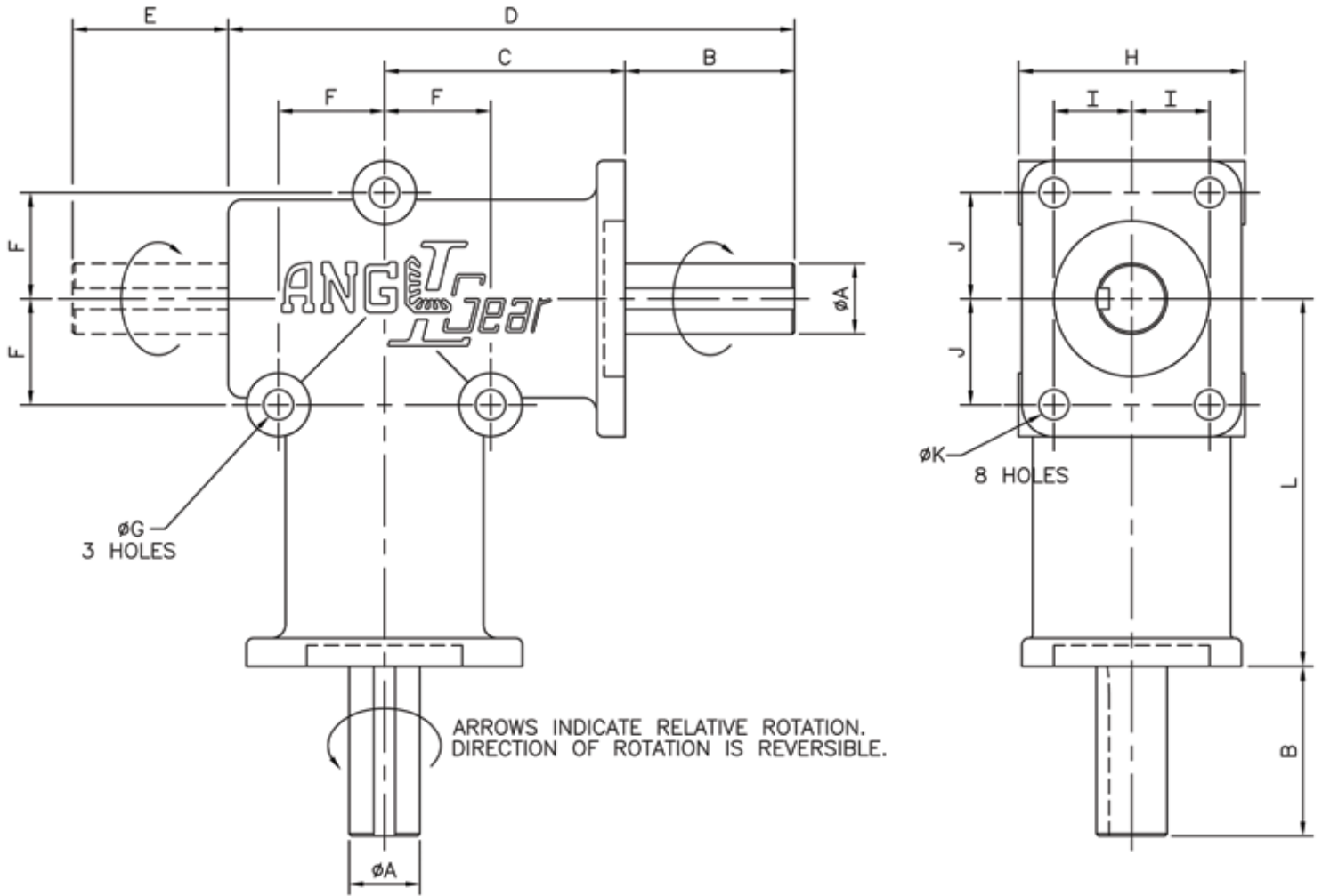

### DIMENSIONS – 2 FLANGE UNITS \*

Model	Type	A	B	C	D	E	F	G	H	I	J	K	L
R3000/R3000-2	2-Way	0.375	0.59	1.385	2.85	-	0.656	0.203	1.25	0.438	0.594	0.177	2.165
R3100/R3100-2	3-Way	0.375	0.59	1.385	2.85	0.59	0.656	0.203	1.25	0.438	0.594	0.177	2.165
R3200/R3200-2	2-Way	0.625	1.50	2.125	5.00	-	0.937	0.265	2.00	0.687	0.937	0.265	3.25
R3300/R3300-2	3-Way	0.625	1.50	2.125	5.00	1.375	0.937	0.265	2.00	0.687	0.937	0.265	3.25

\*Model Numbers followed by "-2" indicates 2:1 reduction. 1:1 & 2:1 units have the same dimensions. Complete outline drawings are available upon request. Shaft diameter tolerances are +0.000/-0.001. All dimensions are in inches and are subject to change.

Keyway Dimensions:      SIZE 1 – R-3000 / R3000-2 / R3100 / R3100-2:      None  
    SIZE 2 – R-3200 / R3200-2 / R3300 / R3300-2:      3/16W x 3/32H x 1 1/2L

# 3 FLANGE UNITS, INCH SERIES

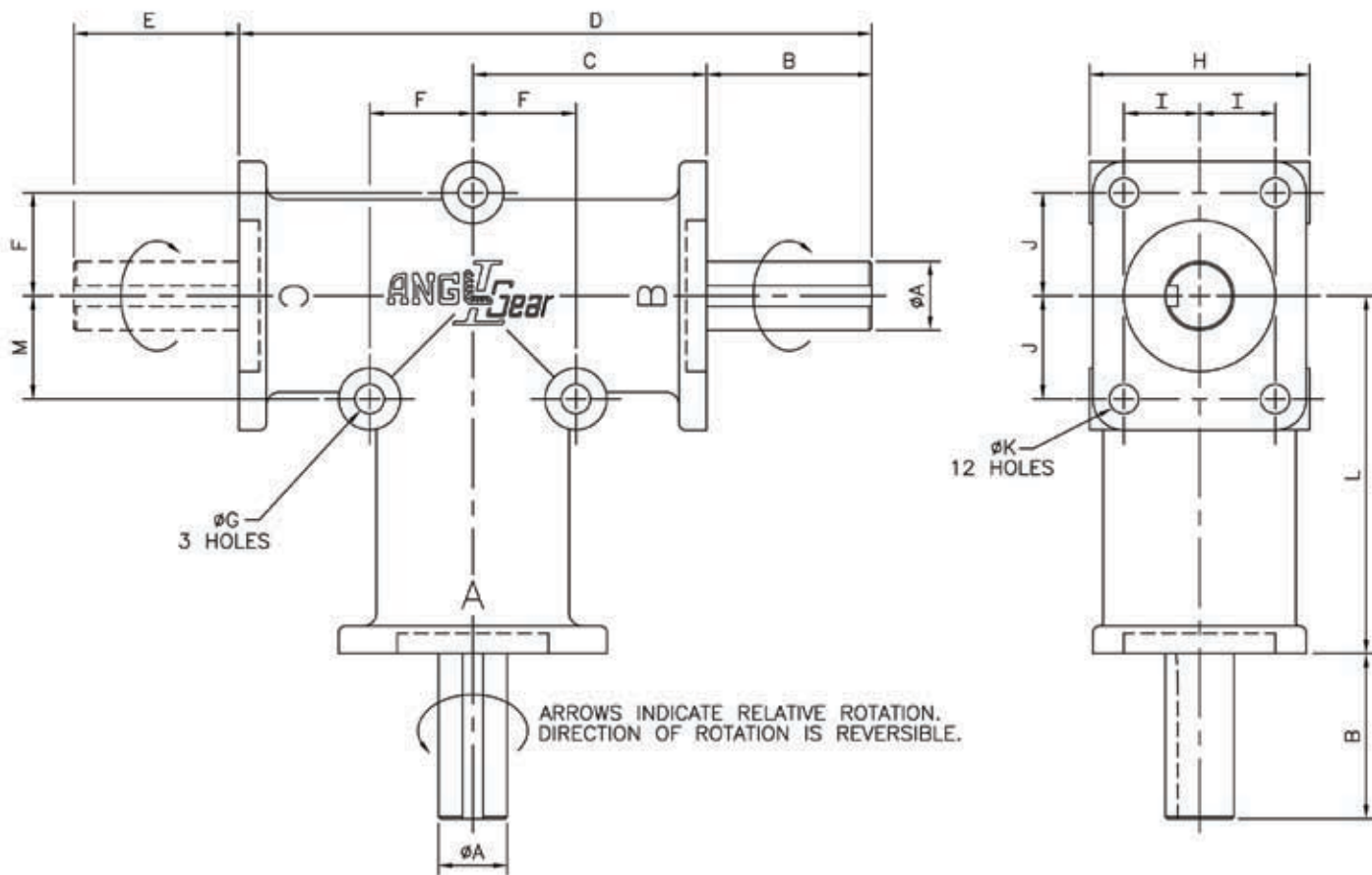

## DIMENSIONS – 3 FLANGE UNITS \*

Model	Type	A	B	C	D	E	F	G	H	I	J	K	L	M
R3003/R3003-2	2-Way	0.375	0.59	1.385	3.36	-	0.656	0.209	1.25	0.438	0.594	0.177	2.165	0.656
R3103/R3103-2	3-Way	0.375	0.59	1.385	3.36	0.59	0.656	0.209	1.25	0.438	0.594	0.177	2.165	0.656
R3203/R3203-2	2-Way	0.625	1.50	2.125	5.75	-	0.937	0.265	2.00	0.687	0.937	0.265	3.25	0.937
R3303/R3303-2	3-Way	0.625	1.50	2.125	5.75	1.50	0.937	0.265	2.00	0.687	0.937	0.265	3.25	0.937
R3330/R3330-2	2-Way	0.75	2.00	3.00	8.00	-	1.50	0.344	3.00	1.125	1.50	0.344	5.00	1.50
R3350/R3350-2	3-Way	0.75	2.00	3.00	8.00	2.00	1.50	0.344	3.00	1.125	1.50	0.344	5.00	1.50
R3400/R3400-2	2-Way	1.00	2.75	3.25	9.25	-	1.75	0.406	4.00	1.50	1.50	0.406	6.00	2.75
R3500/R3500-2	3-Way	1.00	2.75	3.25	9.25	2.75	1.75	0.406	4.00	1.50	1.50	0.406	6.00	2.75
R3570	2-Way	1.00	2.75	3.25	9.25	-	1.75	0.406	4.00	1.50	1.50	0.406	6.00	2.75
R3590	3-Way	1.00	2.75	3.25	9.25	2.75	1.75	0.406	4.00	1.50	1.50	0.406	6.00	2.75

\* Model Numbers followed by "-2" indicates 2:1 reduction. 1:1 & 2:1 units have the same dimensions. Complete outline drawings are available upon request. Shaft diameter tolerances are +0.000/-0.001. All dimensions are in inches and are subject to change.

Keyway Dimensions:	SIZE 1 – R3003 / R3003-2 / R3103 / R3103-2:	None
	SIZE 2 – R3203 / R3203-2 / R3303 / R3303-2:	3/16W x 3/32H x 1 1/4L
	SIZE 3 – R3330 / R3330-2 / R3350 / R3350-2:	3/16W x 3/32H x 1 1/2L
	SIZE 4 – R3400 / R3400-2 / R3500 / R3500-2:	1/4W x 1/8H x 2L
	SIZE 5 – R3570 / R3590:	1/4W x 1/8H x 2L

# SELECTION & ORDERING INFORMATION, INCH SERIES

## Selection Procedure

- Determine the output speed and torque required for your application. The maximum recommended output speed is 3000 rpm for 1:1 units, and 1500 rpm for 2:1 units. 2:1 units are NOT recommended for use as speed increasers.
- Select an application service factor from the chart to the right. Multiply your torque by the selected service factor. If you are unsure of the factor to be used, please consult us.
- Using the chart below, find your output speed on the left. If your speed is not shown, use the next highest speed. Depending on the ratio you need (1:1 or 2:1), follow the chart across until you find a torque value that is larger than your corrected torque value.
- The Unit Size you need will be at the top of that column. There are 5 sizes available. At the bottom of the column is a list of the various models available under the selected size. Select the model number; based on the gear ratio and the number of shafts you need (2 or 3). When ordering, use the model number you selected, along with the ratio desired.
- Check the applied radial and thrust loads on the unit compared with loads in the chart at the bottom of the page. If the applied loads are larger than the chart values, a larger unit must be selected.
- Refer back to pages 4 and 5 for dimensional information on the model you selected.

### SERVICE FACTORS

OPERATING CONDITIONS	SERVICE FACTORS	
	UNIFORM LOAD	MODERATE SHOCK
SERVICE (hours/day)	3	0.7
	8	0.9
	12	1
	24	1.3

$$T \text{ (in.lb)} = 63,000 \times \text{HP} / \text{RPM}$$

$$\text{HP} = T \times \text{RPM} / 63,000$$

OUTPUT SPEED (RPM)	SIZE 1				SIZE 2				SIZE 3				SIZE 4				SIZE 5	
	Ratio 1:1		Ratio 2:1		Ratio 1:1		Ratio 2:1		Ratio 1:1		Ratio 2:1		Ratio 1:1		Ratio 2:1		Ratio 1:1	
	RATINGS*	in.lb	HP	in.lb	HP	in.lb	HP	in.lb	HP	in.lb	HP	in.lb	HP	in.lb	HP	in.lb	HP	in.lb
50	17	0.01	10	0.01	51	0.04	32	0.03	229	0.18	125	0.10	400	0.32	193	0.15	800	0.63
100	16	0.03	10	0.02	49	0.08	30	0.05	215	0.34	117	0.19	370	0.59	182	0.29	740	1.17
200	15	0.05	9	0.03	48	0.15	28	0.09	207	0.66	110	0.35	345	1.10	172	0.55	700	2.22
300	15	0.07	9	0.04	47	0.23	27	0.13	205	0.98	105	0.50	325	1.55	162	0.77	660	3.14
400	14	0.09	8	0.05	47	0.30	26	0.17	203	1.29	100	0.63	310	1.97	154	0.98	625	3.97
500	14	0.11	8	0.06	46	0.37	25	0.20	200	1.59	96	0.76	300	2.38	148	1.17	600	4.76
750	13	0.15	8	0.09	46	0.54	24	0.29	196	2.34	91	1.08	278	3.31	137	1.63	565	6.73
1000	13	0.20	8	0.12	45	0.71	23	0.37	193	3.06	87	1.38	265	4.21	130	2.06	540	8.57
1250	13	0.25	7	0.14	44	0.88	23	0.45	190	3.77	84	1.67	260	5.16	128	2.53	520	10.32
1500	13	0.30	7	0.17	44	1.05	23	0.54	187	4.45	81	1.93	257	6.11	125	2.98	500	11.90
1750	12	0.34			43	1.21			185	5.14			254	7.04			485	13.47
2000	12	0.39			43	1.37			183	5.80			250	7.95			470	14.92
2500	12	0.48			42	1.68			179	7.11			245	9.73			448	17.76
3000	12	0.57			42	1.99			176	8.39			241	11.5			425	20.24

<b>2-WAY</b>	R3000	R3000-2	R3200	R3200-2	R3330	R3330-2	R3400	R3400-2	R3570
<b>3-WAY</b>	R3100	R3100-2	R3300	R3300-2	R3350	R3350-2	R3500	R3500-2	R3590
<b>2-WAY</b>	R3003	R3003-2	R3203	R3203-2					
<b>3-WAY</b>	R3103	R3103-2	R3303	R3303-2					

MODEL DATA (lbs)	R3000		R3100		R3200		R3300		R3330		R3350		R3400		R3500		R3570	R3590
	1:1	2:1	1:1	2:1	1:1	2:1	1:1	2:1	1:1	2:1	1:1	2:1	1:1	2:1	1:1	2:1	1:1	1:1
RADIAL LOAD	25	25	25	25	50	50	50	50	100	100	100	100	100	100	100	100	100	100
THURST LOAD	50	50	50	50	100	100	100	100	200	200	200	200	200	200	200	200	200	200
WEIGHT	0.5	0.5	0.5	0.5	2.2	2.2	2.4	2.4	8.7	8.7	9.0	9.0	14.5	14.5	15	15	17.5	18

\* Unit ratings are: Output Torque in in.lb and Output Power in HP.

## Selection Example

An application to connect a drive-shaft to a fan-shaft at a right-angle. Gearbox ratio to be 1:1. Input and output connections are with timing belt pulleys at 1000 rpm. Transmitted power is 1.34 HP. Operating conditions are moderate shock, 12 hours/day.

- Output speed is 1000 rpm. Operating torque =  $63,000 \times 1.34 \text{ HP} / 1000 \text{ rpm} = 84.4 \text{ in.lb}$ .
- Service factor from chart (12 hours/day, moderate shock) – SF = 1.3. Corrected torque =  $84.4 \times 1.3 = 109.7 \text{ in.lb}$ .
- From ratings chart (output speed = 1000 rpm), unit torque = 193 in.lb (>109.7 in.lb) – Size 3 1:1.
- The model selected is: R3330 for two-way or R3350 for three-way.
- The applied radial loads are calculated to be 74 lb. on each shaft (<100 lb.) which is allowable.
- On pages 4 and 5, the dimensions are checked to confirm available space for model selected.

## 2 FLANGE UNITS, METRIC SERIES

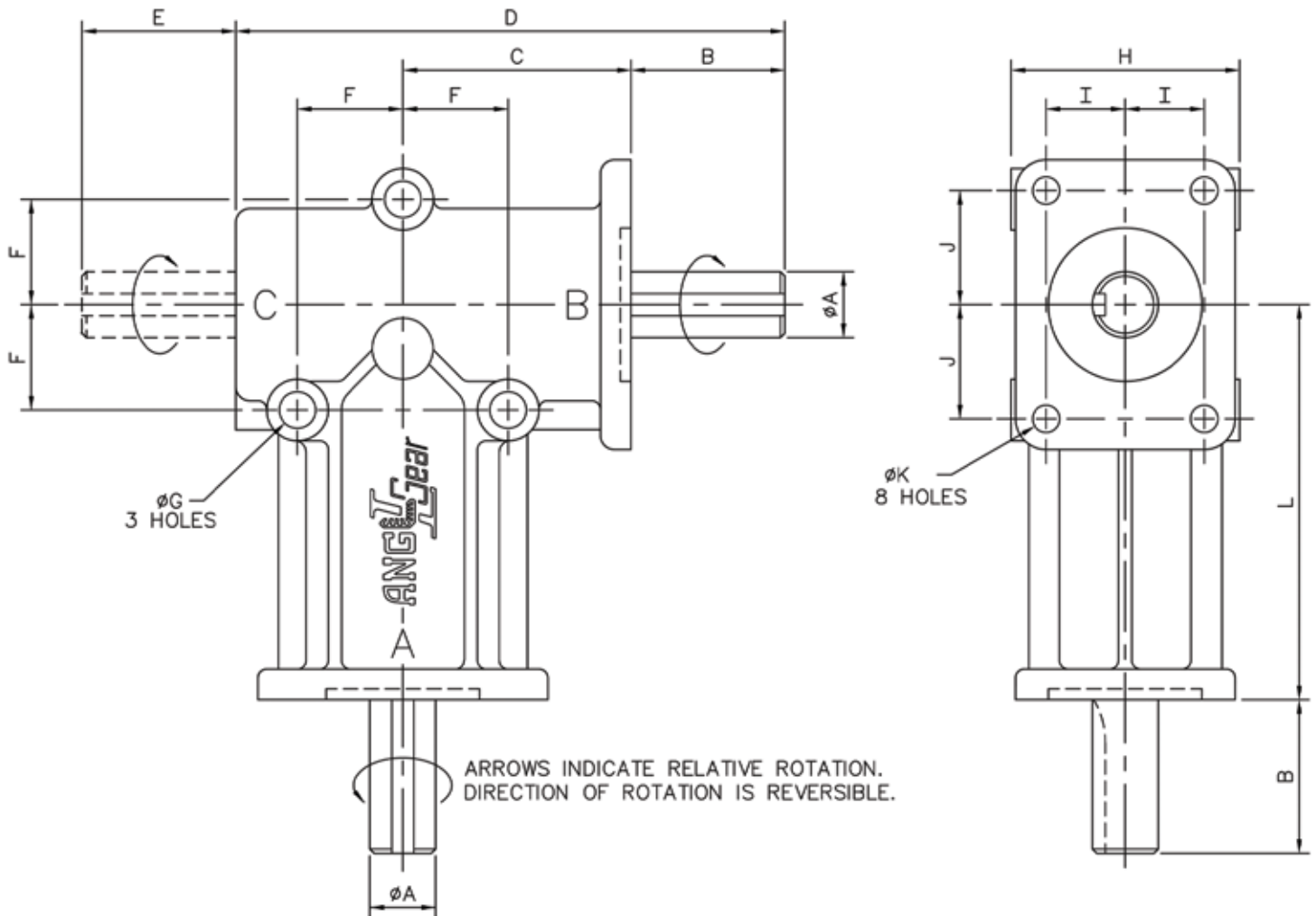

### DIMENSIONS – 2 FLANGE UNITS \*

Model	Type	A	B	C	D	E	F	G	H	I	J	K	L
R3000M/R3000-2M	2-Way	8	15	34	76	-	16	5.2	33	11	15	4.2	60
R3100M/R3100-2M	3-Way	8	15	34	76	15	16	5.2	33	11	15	4.2	60
R3200M/R3200-2M	2-Way	15	35	52	125	-	24	8.3	52	18	26	6.2	90
R3300M/R3300-2M	3-Way	15	35	52	125	35	24	8.3	52	18	26	6.2	90

Model numbers followed by "-2" indicates 2:1 reduction. 1:1 & 2:1 units have the same dimensions. Complete outline drawings are available upon request. Shaft diameter tolerances are ISO f7. All dimensions are in millimeters and are subject to change.

Keyway Dimensions:      SIZE 1 - R3000M / R3000-2M / R3100M / R3100-2M:      None  
    SIZE 2 - R3200M / R3200-2M / R3300M / R3300-2M:      5W x 2.5H x 25L



## 3 FLANGE UNITS, METRIC SERIES

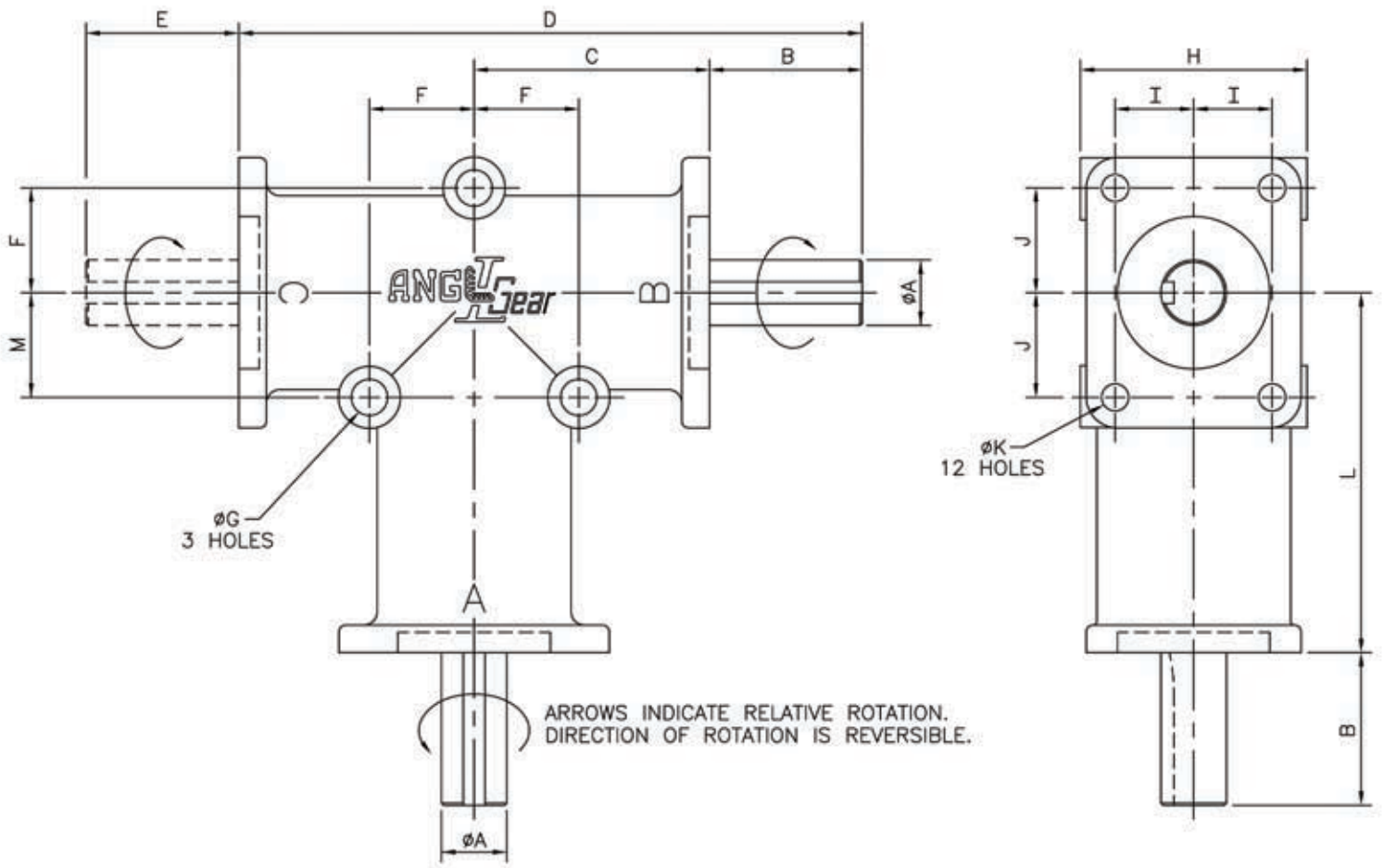

### DIMENSIONS – 3 FLANGE UNITS \*

Model	Type	A	B	C	D	E	F	G	H	I	J	K	L	M
R3003M/R3003-2M	2-Way	8	15	35	85	-	16.5	5.2	33	11	15	4.2	55	16.5
R3103M/R3103-2M	3-Way	8	15	35	85	15	16.5	5.2	33	11	15	4.2	55	16.5
R3203M/R3203-2M	2-Way	15	35	54	143	-	24	8.3	52	18	24	6.2	82.5	24
R3303M/R3303-2M	3-Way	15	35	54	143	35	24	8.3	52	18	24	6.2	82.5	24
R3330M/R3330-2M	2-Way	20	50	75	200	-	38	8.3	76	27	38	8.3	140	38
R3350M/R3350-2M	3-Way	20	50	75	200	50	38	8.3	76	27	38	8.3	140	38
R3400M/R3400-2M	2-Way	25	70	80	230	-	45	10.3	100	38	38	10.3	150	70
R3500M/R3500-2M	3-Way	25	70	80	230	70	45	10.3	100	38	38	10.3	150	70
R3600M/R3600-2M	2-Way	35	70	80	230	-	45	10.3	100	38	38	10.3	150	70
R3700M/R3700-2M	3-Way	35	70	80	230	70	45	10.3	100	38	38	10.3	150	70

Model numbers followed by "-2" indicates 2:1 reduction. 1:1 & 2:1 units have the same dimensions. Complete outline drawings are available upon request. Shaft diameter tolerances are ISO f7. All dimensions are in millimeters and are subject to change.

Keyway Dimensions:    SIZE 1 – R3003M / R3003-2M / R3103M / R3103-2M:    None  
                                   SIZE 2 – R3203M / R3203-2M / R3303M / R3303-2M:    5W x 2.5H x 25L  
                                   SIZE 3 – R3330M / R3330-2M / R3350M / R3350-2M:    6W x 3H x 40L  
                                   SIZE 4 – R3400M / R3400-2M / R3500M / R3500-2M:    8W x 3.5H x 60L  
                                   SIZE 5 – R3600M / R3600-2M / R3700M / R3700-2M:    10W x 4H x 55L

# SELECTION & ORDERING INFORMATION, METRIC SERIES

## Selection Procedure

1. Determine the output speed and torque required for your application. The maximum recommended output speed is 3000 rpm for 1:1 units, and 1500 rpm for 2:1 units. 2:1 units are NOT recommended for use as speed increasers.
2. Select an application service factor from the chart to the right. Multiply your torque by the selected service factor. If you are unsure of the factor to be used, please consult us.
3. Using the chart below, find your output speed on the left. If your speed is not shown, use the next highest speed. Depending on the ratio you need (1:1 or 2:1), follow the chart across until you find a torque value that is larger than your corrected torque value.
4. The Unit Size you need will be at the top of that column. There are 5 sizes available. At the bottom of the column is a list of the various models available under the selected size. Select the model number, based on the gear ratio and the number of shafts you need (2 or 3). When ordering, use the model number you selected, along with the ratio desired.
5. Check the applied radial & thrust loads on the unit compared with the loads in the chart at the bottom. If the applied loads are larger than the chart values, a larger unit must be selected.
6. Refer back to pages 4 & 5 for dimensional information on the model you selected.

### SERVICE FACTORS

OPERATING CONDITIONS	UNIFORM LOAD	MODERATE SHOCK	
SERVICE (hours/day)	3	1	1.3
	8	1.3	1.4
	12	1.4	1.8
	24	1.8	2.5

$$T \text{ (Nm)} = 9,550 \times \text{kW} / \text{RPM}$$

$$\text{kW} = T \times \text{RPM} / 9,550$$

OUTPUT SPEED (RPM)	SIZE 1				SIZE 2				SIZE 3				SIZE 4				SIZE 5			
	1:1		2:1		1:1		2:1		1:1		2:1		1:1		2:1		1:1		2:1	
	T	kW	T	kW	T	kW	T	kW	T	kW	T	kW	T	kW	T	kW	T	kW	T	kW
50	4.70	0.02	1.25	0.01	16.60	0.09	5.02	0.03	50.5	0.26	27	0.14	89	0.47	39.1	0.20	132	0.69	72.2	0.38
100	4.20	0.04	1.09	0.01	14.50	0.15	4.65	0.05	44	0.46	26	0.27	79	0.83	37.4	0.39	118	1.24	67.7	0.71
200	3.70	0.08	0.96	0.02	12.60	0.26	4.42	0.09	38	0.80	24.5	0.51	69	1.45	36.1	0.76	102	2.14	63.3	1.33
300	3.40	0.11	0.91	0.03	11.60	0.36	4.20	0.13	34.7	1.09	23	0.72	62.9	1.98	34.9	1.10	93.2	2.93	61	1.92
400	3.20	0.13	0.86	0.04	10.90	0.46	3.97	0.17	32.5	1.36	22	0.92	58.7	2.46	33.2	1.39	86.9	3.64	56.6	2.37
500	3.07	0.16	0.84	0.04	10.45	0.55	3.86	0.20	31.1	1.63	21.5	1.13	55.9	2.93	32.3	1.69	82.7	4.33	55.1	2.88
750	2.79	0.22	0.77	0.06	9.70	0.76	3.64	0.29	28.7	2.25	20.3	1.59	50.2	3.94	30.2	2.37	74.1	5.82	50.4	3.96
1000	2.60	0.27	0.69	0.07	9.20	0.96	3.37	0.35	27.1	2.84	19	1.99	46.3	4.85	28.1	2.94	68.3	7.15	47.6	4.98
1250	2.48	0.32	0.65	0.09	8.83	1.16	3.20	0.42	26	3.40	18	2.36	43.5	5.69	26	3.40	64.1	8.39	44.1	5.77
1500	2.36	0.37	0.62	0.10	8.45	1.33	3.11	0.49	24.8	3.90	17.9	2.81	41.3	6.49	24.9	3.91	60.7	9.53	42.2	6.63
1750	2.25	0.41			8.00	1.47			23.7	4.34			39.3	7.20			57.4	10.5		
2000	2.18	0.46			7.90	1.65			22.8	4.77			37.9	7.94			55.5	11.6		
2500	2.06	0.54			7.80	2.04			21.3	5.58			35.3	9.24			51.6	13.5		
3000	1.95	0.61			7.70	2.42			20.2	6.35			33.3	10.5			48.6	15.3		

2-WAY	R3000M	R3000-2M	R3200M	R3200-2M	R3330M	R3330-2M	R3400M	R3400-2M	R3600M	R3600-2M
3-WAY	R3100M	R3100-2M	R3300M	R3300-2M	R3350M	R3350-2M	R3500M	R3500-2M	R3700M	R3700-2M
2-WAY	R3003M	R3003-2M	R3203M	R3203-2M						
3-WAY	R3103M	R3103-2M	R3303M	R3303-2M						

MODEL DATA (kg)	R3000M		R3100M		R3200M		R3300M		R3330M		R3350M		R3400M		R3500M		R3600M		R3700M		
	1:1	2:1	1:1	2:1	1:1	2:1	1:1	2:1	1:1	2:1	1:1	2:1	1:1	2:1	1:1	2:1	1:1	2:1	1:1	2:1	
RADIAL LOAD	11.4	11.4	11.4	11.4	22.7	22.7	22.7	22.7	45.4	45.4	45.4	45.4	45.4	45.4	45.4	45.4	45.4	45.4	45.4	45.4	45.4
THRUST LOAD	22.7	22.7	22.7	22.7	45.4	45.4	45.4	45.4	90.7	90.7	90.7	90.7	90.7	90.7	90.7	90.7	90.7	90.7	90.7	90.7	90.7
WEIGHT	0.23	0.23	0.23	0.23	1.00	1.00	1.09	1.09	3.95	3.95	4.08	4.08	6.58	6.58	6.80	6.80	7.94	7.94	8.16	8.16	

\* Unit ratings are: Output Torque in Nm and Output Power in kW.

## Selection Example

An application to connect a drive-shaft to a fan-shaft at a right-angle with a 1:1 ratio. Input & output connections with timing belt pulleys at 1,000 rpm. Input power is 1 kW. Operating conditions are moderate shock, 12 hr/day.

1. Output speed is 1000 rpm. Operating torque =  $9,550 \times 1 \text{ kW} / 1000 \text{ rpm} = 9.55 \text{ Nm}$ .
2. Service factor from chart (12 hours/day, moderate shock) - SF=1.3. Corrected torque =  $9.55 \times 1.3 = 12.42 \text{ Nm}$ .
3. From ratings chart (output speed = 1000 rpm), unit torque = 27.1 Nm (> 12.42 Nm) - Size 3 1:1.
4. The model selected is: R3330M for two-way or R3350M for three-way.
5. The applied radial loads are calculated to be 33.6 kg on each shaft (< 45.4 kg), which is allowable.
6. On pages 7 & 8, the dimensions are checked to confirm available space for model selected.

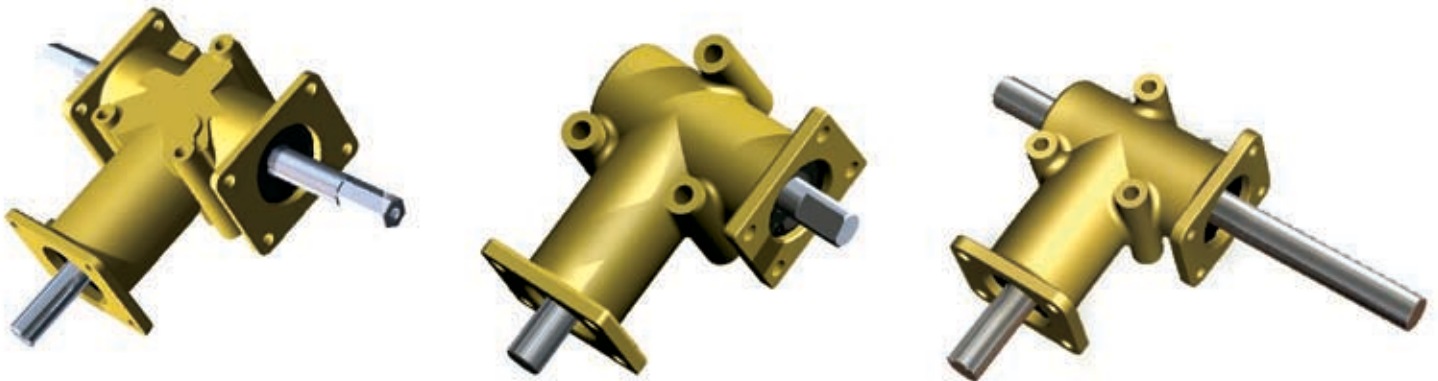

The photo above shows examples of special units that Andantex USA has designed/modified to meet our customers' requirements. We will design/modify any unit to meet your design specifications.

- Special models can be provided with:
- Various shaft lengths and configurations.
  - Same relative rotation of input-to-output shafts (BO)
  - 3-way units with counter-rotating output shafts.
  - Shafts with flats, splines, holes, etc.
  - Modifications to the mounting flanges and housing.
  - Special materials, bearings, seals, greases, coatings, etc.

## Service & Replacement Parts

All units can be serviced at our factory in Wanamassa, NJ. Field repairs are not covered under our warranty. Unit parts lists are available upon request. Spare parts may be purchased from our factory, and are non-returnable.

### Warranty

ANDANTEK USA Inc., the manufacturer, warrants that for a period of 12 months from the date of installation or 18 months from the date of shipment, it will repair, or at its option, replace any new unit which proves defective in material or workmanship, or which does not conform to applicable drawings and specifications approved by the manufacturer. All repairs and replacements shall be F.O.B. factory. All claims must be made in writing to the manufacturer.

In no event, and under no circumstances shall the manufacturer be liable for (a) damages in shipment; (b)

failures or damages due to misuse, abuse, improper installation or abnormal conditions of temperature, dirt, water or corrosives; (c) failures due to operation, intentional or otherwise, above rated capacities, and (d) non-authorized expenses for removal, inspection, transportation, repair or rework. Nor shall the manufacturer ever be liable for consequential and incidental damages, or in any amount greater than the purchase price of the unit.

This warranty is in LIEU OF ALL OTHER WARRANTIES, EXPRESS OR IMPLIED, INCLUDING (BUT NOT LIMITED TO) ANY IMPLIED WARRANTIES OF MERCHANT ABILITY OR FITNESS FOR A PARTICULAR PURPOSE. THE TERMS OF THIS WARRANTY CONSTITUTE ALL BUYER'S OR USER'S SOLE AND EXCLUSIVE REMEDY, AND ARE IN LIEU OF ANY RIGHT TO RECOVER FOR NEGLIGENCE, BREACH OF WARRANTY, STRICT TORT LIABILITY OR UPON ANY OTHER THEORY.

**ANDANTEX**  
USA Inc.

1705 Valley Road • Wanamassa, NJ 07712  
Phone: 800.713.6170 • 732.493.2812 • Fax: 732.493.2949 • E-mail: [info@andantex.com](mailto:info@andantex.com) • [www.andantex.com](http://www.andantex.com)